

Brandsafe

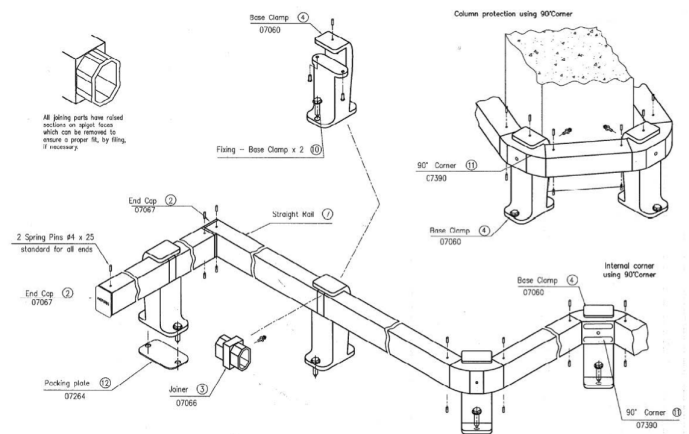

MBT Heavy Duty Rail

An essential protective solution designed for warehouses, factories, and distribution centres. This robust barrier is engineered to shield property, equipment, walls, and columns from low-speed impacts typically encountered in such environments.



Features and Benefits

- Ideal for providing a buffer between walls and high traffic routes.
- Separating forklifts and other MHE from property walls.
- Fully modular system.

Technical Details

- Made from galvanised steel.
- 51mm x 76mm box section galvanised rail with aluminum feet, ends and corners.
- Finished height - 262mm above floor level.
- Aluminium foot with aluminum fixings.

Material	Galvanised steel
Dimensions	51mm x 76mm box section galvanised rail with aluminum feet, ends and corners
Height	262mm above floor level
Fixings	(2) M10x80mm expandable rawl shields and bolts per support foot
Max distance between feet	2000mm
Max distance of foot from end or corner	150mm
Finished depth	136mm