

Brandsafe

Armco 760D Safety Barrier

760D Armco safety barriers are an ideal solution for industrial areas with a high risk of vehicular collisions. With double crash barriers, total coverage is provided against harmful Forklift impacts, etc. Like the rest of our Armco barriers, this is a versatile system that can be customised with pedestrian handrails, safety ends and corners to create a bespoke solution.



Features and Benefits

- 760 mm high Armco barrier with forklift impact rail.
- Double crash barriers for total impact protection.
- Provides a high-level and low-level impact protection solution.
- Handrail options available to create pedestrian walkways.
- Ideal for potentially high-risk, high-impact areas.
- We recommend 1.6 M post centres for high impact areas and 3.2 M post centres for low impact areas.
- Should be fixed with M16/M20 thru bolts.

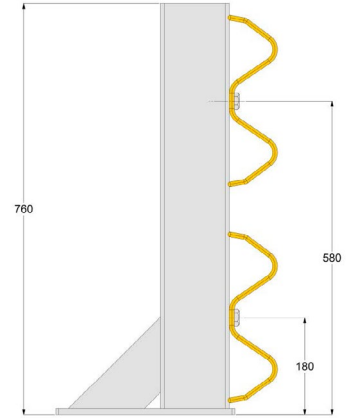
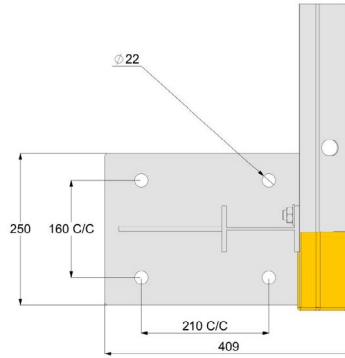
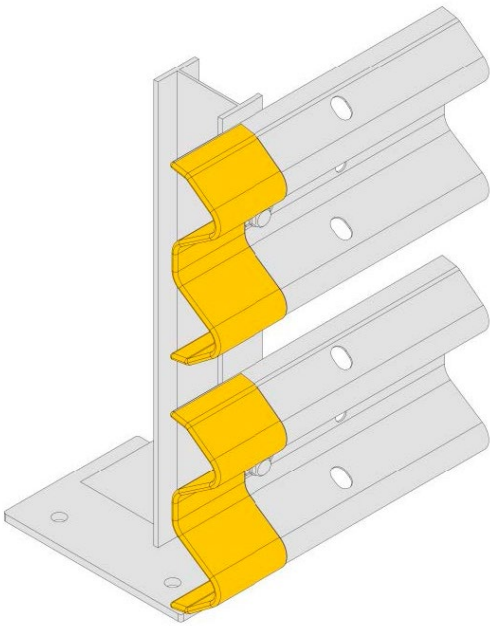

Material	Mild steel
Height	760 mm / 180 mm to centre of low barrier / 580 mm to centre of upper barrier
Colour options	Hot dip galvanised to BS EN ISO 1461
Safety reflectors	Diamond grade to all accessories
Base plate	Type B - 330 mm x 250 mm x 12 mm thick
Footprint depth	409 mm
Floor anchors	RAWL M16 x 150 mm galvanised thrubolts (4)
Fixing hole	22 mm
Drill diameter	16 mm
Drill depth	150 mm