

MBT Heavy Duty Rail

The MBT (Modular 'B' Type) has many applications for protecting property, equipment, walls and columns from low speed impacts from typical environmental hazards that are experienced in the warehouse.

MBT is designed to protect your property and reduce the risk of accidental damage. Vehicles and roll cages of all types and sizes reversing and manoeuvring around sites can cause damage to walls, loading decks and security fencing.

Product Features

Galvanised, hot dipped finish for a tough service life with aluminum feet, ends and corners, this adaptable steel barrier system can be assembled to any length and in unbroken lines; can be terminated for access points and of course go around internal or external corners to suit your site.

Our MBT is one of our most robust and versatile products. Suitable for both internal and external use, this modular galvanised steel rail provides practicality with durability. The modular nature of the product allows for easy planning and installation and can be adapted to the most challenging briefs.

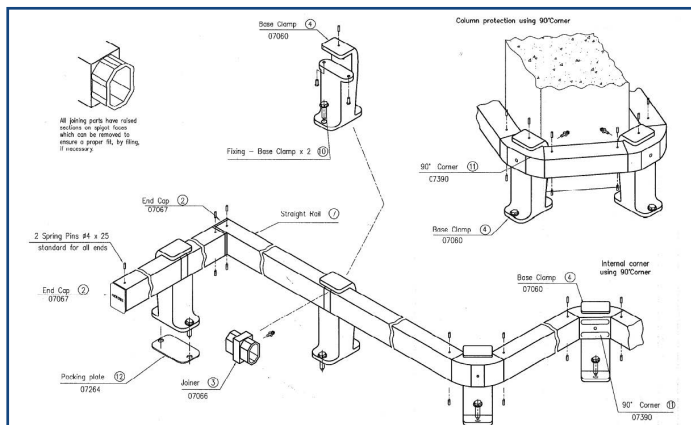

Technical Details

51 mm x 76mm box section galvanised rail with aluminium feet, ends and corners

Finished height - 262mm above floor level

Aluminium foot with aluminium fixings

Fully modular system

Fixed using two M10x80mm expandable rawl shields and bolts per support foot

Max distance between feet - 2000mm

Max distance of foot from end or corner - 150mm

Finished depth - 136mm