

Brandsafe

Armco 360 Safety Barrier

The **Armco 360 safety barrier** is an ideal, cost-effective solution for perimeter wall and equipment protection in the industrial workplace. It can be installed with the purpose of keeping traffic away from walls and crucial equipment, as well as keeping pedestrians safe from moving vehicles.



Features and Benefits

- 360 mm high Armco barrier with forklift impact rail.
- Ideal for perimeter wall and equipment protection.
- Optional handrails for creating pedestrian walkways.
- A cost-effective solution for low-level traffic impact protection.
- Comes complete with forklift impact rails.
- We recommend 1.6 M post centres for high impact areas and 3.2 M post centres for low impact areas.

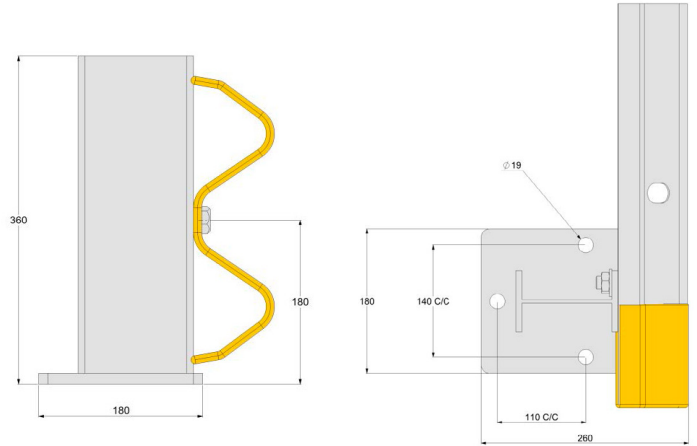
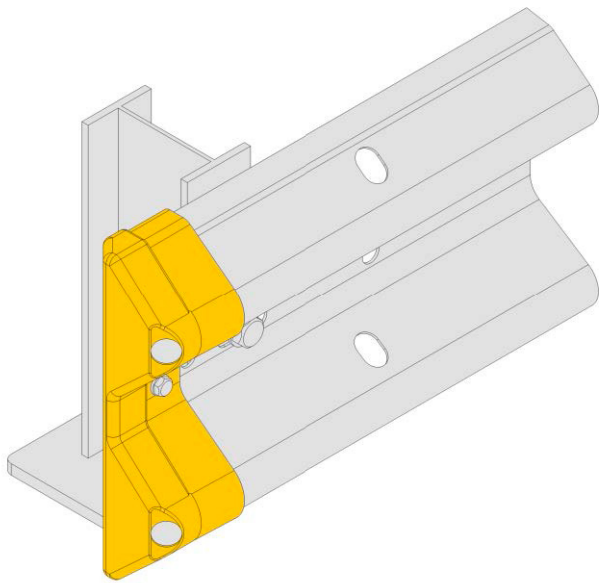

Material	Mild steel
Height	360 mm
Fixing holes	3 per baseplate
Colour options	Hot dip galvanised
Safety reflectors	2 no. 25 mm diamond grade reflectors
Base plate	180 mm x 180 mm x 10 mm
Edge spacing	Recommended 80 mm (min)
Footprint depth	257 mm
Centre spacing	140 mm (actual) recommended 90 mm (min)
Floor anchors	M16 x 150 mm galvanised thrubolts